

**MONITORE A COMANDO MANUALE Mod. FI – MG-4
A SINGOLO VOLANTINO**
MANUAL CONTROL MONITOR Mod. FI – MG-4
WITH SINGLE HANDWHEEL

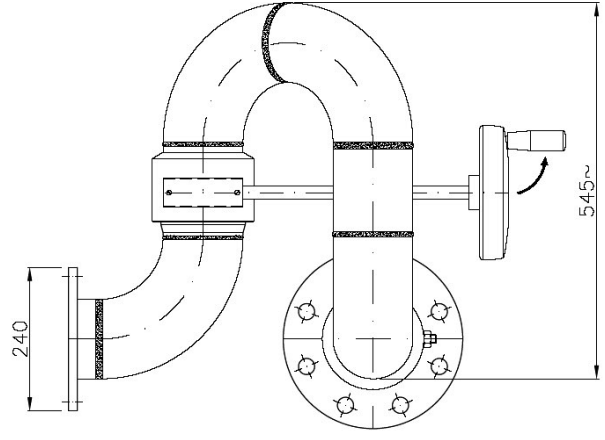

- = Corpo: Acciaio al carbonio o in acciaio inox
- = Giunti: Elicoidali irreversibili montati su doppia corona di sfere ingrassati a vita.
- = Rotazione: 360° manuale con leva di bloccaggio
- = Alzo: +90° - 90° tramite volantino
- = Attacco canne: flangiato o filettato
- = Verniciatura: con vernici epossiviniliche e finitura con smalto poliuretano color rosso RAL 3000.
- = Body: Carbon steel or Stainless steel
- = Joints: Irreversible helicoidal mounted on double ring of spheres with graser and locking device.
- = Rotation: 360° manual locking hand grip
- = Elevation: + 90° - 90° by handwheel
- = Branchpipe connection: flanged threaded
- = Finishing: Epoxi – primer and polyurethanic enamel color red RAL 3000.

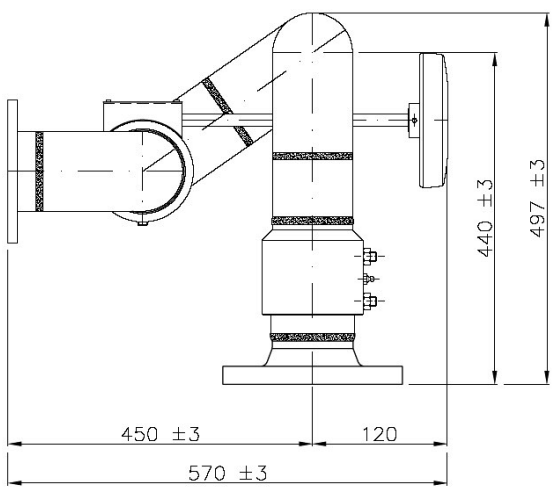

MODELLO MODEL	Diametro flange ingresso Inlet connections size	Corpo Body	Portata massima Max. Capacity Lt/1'	Materiale Corpo Body Material	Peso Weight
FI – MG-4	4" / 6" UNI / ANSI	4"	6.000	Acc. al carbonio Carbon Steel	50 Kg
				Acc. Inox 304/316 Stainless stell	45 Kg

